

WELD FLANGES

- STEEL CONSTRUCTION
- BLACK PHOSPHATE FINISH (SUITABLE FOR WELDING)
- FLANGED DESIGN MINIMISES WARPAGE
- ' O ' RING PORT ENSURES LEAK PROTECTION

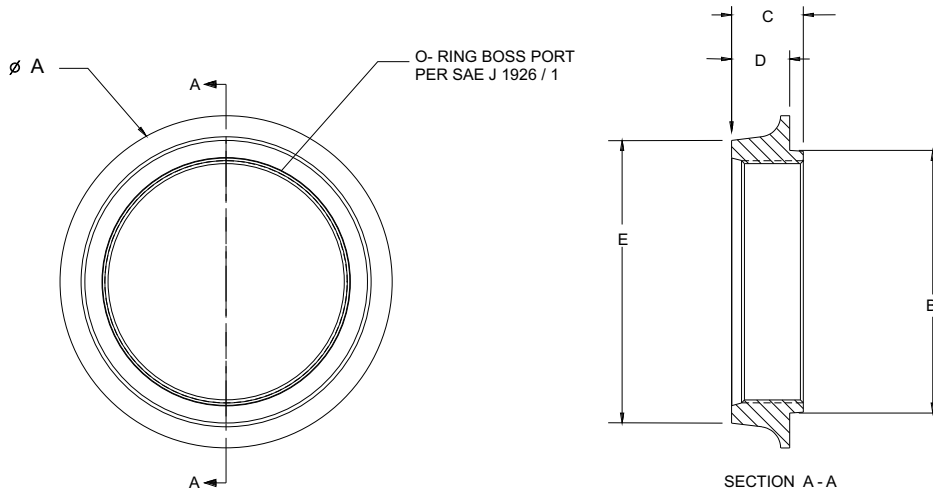

MODEL	PORT U.N.F	PORT B / N		A	B	C	D	E
TWF	04U - 7 / 16" - 20	-	IN	1.50 "	.93 "	.56 "	.31 "	1.0 "
			MM	38.10	23.62	14.22	7.87	25.40
TWF	05U - 1 / 2" - 20	-	IN	1.50 "	.93 "	.56 "	.31 "	1.0 "
			MM	38.10	23.62	14.22	7.87	25.40
TWF	06U - 9 / 16" - 18	-	IN	1.50 "	.93 "	.56 "	.31 "	1.0 "
			MM	38.10	23.62	14.22	7.87	25.40
TWF	08U - 3 / 4" - 16	04 - 1/2"	IN	1.50 "	.93 "	.56 "	.31 "	1.0 "
			MM	38.10	23.62	14.22	7.87	25.40
TWF	10U - 7 / 8" - 14	-	IN	2 .13 "	1.38 "	.69 "	.44 "	1.44 "
			MM	54.10	35.05	17.52	11.17	36.57
TWF	12U - 1 - 1 / 16" - 12	06 - 3/4"	IN	2 .13 "	1.38 "	.69 "	.44 "	1.44 "
			MM	54.10	35.05	17.52	11.17	36.57
TWF	14U - 1 - 3 / 16" - 12	-	IN	2 .38 "	1.66 "	.75 "	.50 "	1.75 "
			MM	60.45	42.16	19.05	12.70	44.45
TWF	16U - 1 - 5 / 16" - 12	08 - 1"	IN	2 .38 "	1.66 "	.75 "	.50 "	1.75 "
			MM	60.45	42.16	19.05	12.70	44.45
TWF	20U - 1 - 5 / 8" - 12	10 - 1-1/4"	IN	2 .69 "	2 .00 "	.75 "	.50 "	2.13 "
			MM	68.32	50.80	19.05	12.70	54.10
TWF	24U - 1 - 7 / 8" - 12	12 - 1-1/2"	IN	3 .00 "	2 .25 "	.75 "	.50 "	2 .38 "
			MM	76.20	38.10	19.05	12.70	60.45
TWF	32U - 2 - 1 / 2" - 12	16 - 2"	IN	3 .50 "	2 .63 "	.86 "	.60 "	2 .88 "
			MM	88.90	38.10	21.74	15.34	73.15
TWF	48U - 3 - 3 / 8" - 12	22 - 3"	IN	4 .63 "	3 .66 "	1.00 "	.81 "	3 .94 "
			MM	117.60	92.96	25.40	20.57	100.07

MODEL CODE

T W F	**	U*
SERIES	SIZE	U- UNF THREAD(SAE) B- BSPP THREAD N - NPT THREAD

* FOR OPTIONAL THREADS BSPP / NPT CONSULT FACTORY

DIMENSIONS IN MM FOR REFERENCE ONLY