

LEVEL GAUGE

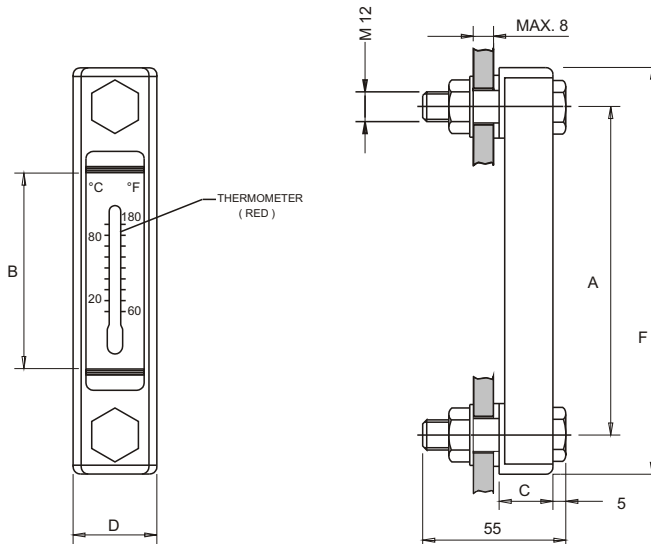

- 'O' RING TYPE CONSTRUCTION
- 3 SIZES 3", 5" & 10" BETWEEN BOLT CENTRES
- FOR NON PRESSURISED TANKS ONLY
- CAN BE MOUNTED ON TAPPED HOLES
- SUITABLE FOR MINERAL / PETROLEUM BASED OILS
- MAXIMUM TEMPERATURE 80° C



MODEL	A	B	C	D	F	WT KGS
LG2 - 03	76	37	20	34	108	0.20
LG2 - 05	127	76	20	34	159	0.25
LG2 - 10	254	203	20	34	286	0.30

MODEL CODE : ASSEMBLY

LG 2	- 05	T	- M 10
SERIES	SIZE INCH	FEATURE OPTIONAL #	FEATURE SPECIAL #
LG 2	03 - 3"	T - THERMOMETER (OMIT IF NOT REQD)	M12 - STD (M12 X 1.75 BOLT)
	05 - 5"		M10 - SPECIAL (M10 X 1.50 BOLT)
	10 - 10"		UNC - SPECIAL (1/2" - 13 UNC)

NOTE : BOLT TORQUE TO BE LIMITED TO 3 FT LBS
OPTIONAL / SPECIAL FEATURE - OMIT IF NOT REQUIRED

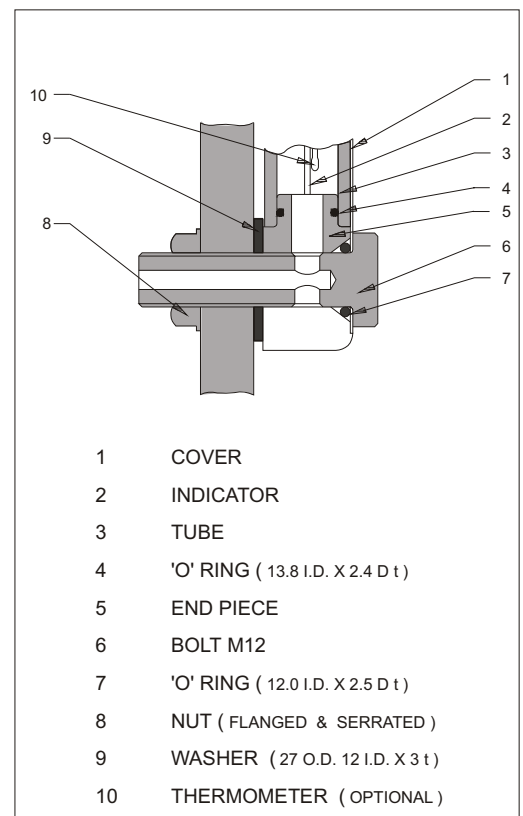

LEVEL GAUGE

- 'O' RING TYPE CONSTRUCTION / STURDY DIE CAST COVER
- 3 SIZES 3", 5" & 10" BETWEEN BOLT CENTRES
- FOR NON PRESSURISED TANKS ONLY
- CAN BE MOUNTED ON TAPPED HOLES
- SUITABLE FOR MINERAL / PETROLEUM BASED OILS
- MAXIMUM TEMPERATURE 80° C

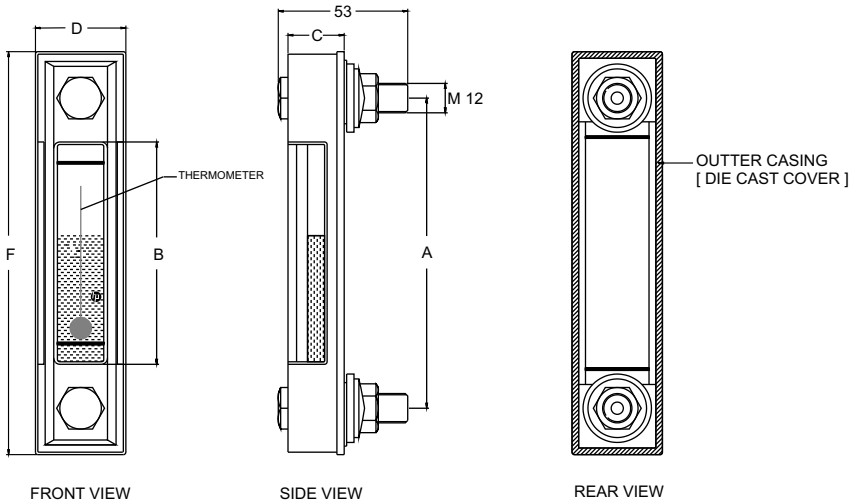
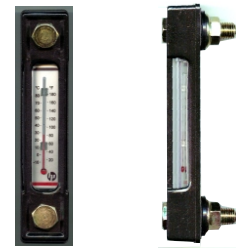

MODEL	A	B	C	D	F	WT KGS
LG 6 - 03	76.2	34	23	35	111	0.17
LG 6 - 05	127.0	89	23	35	162	0.19
LG 6 - 10	254.0	89	23	35	289	0.40

MODEL CODE : ASSEMBLY

LG	- 05	T	- M 10
SERIES	SIZE INCH	FEATURE OPTIONAL #	FEATURE SPECIAL #
LG 6	03 - 3"	T - THERMOMETER (OMIT IF NOT REQD)	M12 - STD (M12 X 1.75 BOLT)
	05 - 5"		M10 - SPECIAL (M10 X 1.50 BOLT)
	10 - 10"		UNC - SPECIAL (1/2" - 13 UNC)

NOTE : BOLT TORQUE TO BE LIMITED TO 3 FT LBS

OPTIONAL / SPECIAL FEATURE - OMIT IF NOT REQUIRED

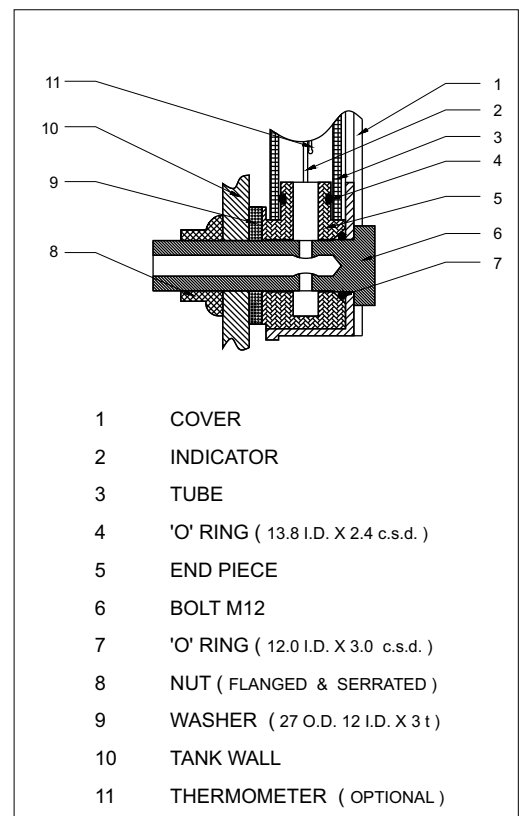

DIMENSIONS IN MM FOR REFERENCE ONLY